



# *Introducción*

*A nuestros clientes y público en general:*

*DIALUC, En su empeño por brindarle productos y servicios de calidad, a preparado para usted su nueva edición del catalogo de perfiles de aluminio de líneas comerciales y arquitectónicas, que le permitirán a usted la búsqueda sencilla del producto de su preferencia y el que más vaya acorde con sus necesidades.*

*En DIALUC le garantizamos que todos los productos y servicios que ofrecemos son revisados bajo la más estrictas normas de calidad, lo que nos permite aspirar a un crecimiento integral y sostenido en busca de trascender en el mercado nacional.*

*Ser Empresa líder y de mayor credibilidad en el ramo, es nuestra visión, y con su confianza estamos seguros de lograr su satisfacción a través de productos y servicios de la mejor calidad.*

*Respaldar los hechos nuestra filosofía es para DIALUC, un COMPROMISO TOTAL.*

Distribuidor autorizado



Calidad Certificada  
ISO 9002

# I N D I C E

## *Introducción*

<i>Indice</i> .....	1
<i>Fijos Bolsa 1 1/2"</i> .....	2
<i>Fijos Bolsa 2"</i> .....	3
<i>Fijos Bolsa 3"</i> .....	4
<i>Ventilas de Proyección</i> .....	5
<i>Corrediza 1 1/2"</i> .....	7
<i>Corrediza 2"</i> .....	8
<i>Corrediza 3"</i> .....	10
<i>Puerta Batiente (económica)</i> .....	12
<i>Puerta Batiente 1.5"</i> .....	13
<i>Puerta Batiente 1.75"</i> .....	14
<i>Perfiles diversos</i> .....	15
<i>Línea Baño (económica)</i> .....	19
<i>Línea Baño (de lujo)</i> .....	20
<i>Celocias</i> .....	21
<i>Recubrimientos</i> .....	22
<i>Sifón</i> .....	23
<i>Perfiles Standard</i> .....	24

Distribuidor autorizado



Calidad Certificada  
ISO 9002



## Es el metal más abundante y útil de nuestro planeta

En la tabla periódica de los elementos se le clasifica como metal sólido, símbolo Al, número atómico 13, valencia 3 y masa atómica de 26.98.

En casi toda la corteza terrestre se encuentra el aluminio, siempre combinado y nunca en su estado metálico puro.

El mineral más adecuado para extraer el aluminio es la bauxita, en este proceso se distinguen 3 etapas.

- a) Mineral
- b) Refinación
- c) Reducción

a) La bauxita se extrae de minas que por lo general son depósitos poco profundos, se lava, se seca y se lleva a las refineras.

b) La refinación consiste en extraer la alumina de la bauxita mediante una solución de sosa caustica en caliente y a baja presión, luego calcinación de la alumina obtenida por hidrólisis; decantación y filtrado.

c) Reducción. electrólisis de la alumina mezclada con criolita a 1000°C, el aluminio corre al fondo de la cuba y de aquí se bombea a los crisoles, se verifica la calidad y se deposita en las lingoteras.

En **DIALUC**, casi todos los perfiles de este catálogo se fabrican en la aleación de aluminio 6063, esta aleación es la más usada universalmente por sus excelentes propiedades, como resistencia a la corrosión; resistencia estructural; buena extruibilidad; buena para recibir acabados como el anodizado.

### ORDEN DE ABUNDANCIA DE ELEMENTOS EN LA CORTEZA TERRESTRE

ELEMENTO	PARTES X1000
OXIGENO	446.1
SILICIO	277.2
ALUMINIO	81.3
HIERRO	50.0
CALCIO	36.9
SODIO	28.3
POTASIO	25.9
MAGNESIO	20.9

### MATERIAL NECESARIO PARA PRODUCIR 1 TONELADA DE ALUMINIO



Distribuidor autorizado



Calidad Certificada  
ISO 9002

# Línea de 1½"

## FIJOS BOLSA

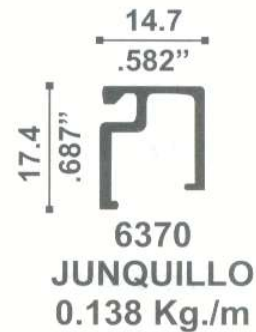
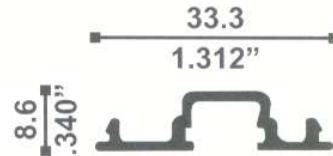
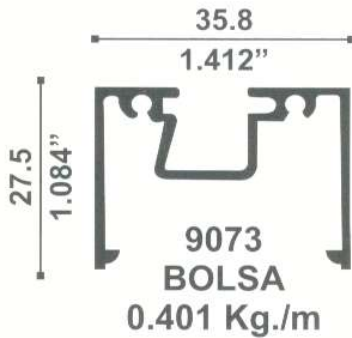

Largo Estándar 6.10 mts.

Distribuidor autorizado



Calidad Certificada  
ISO 9002

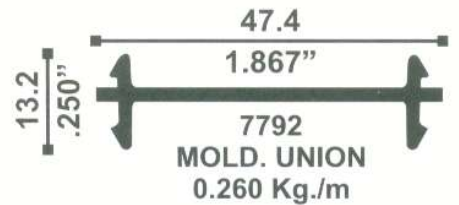
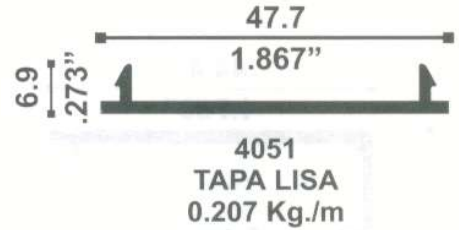
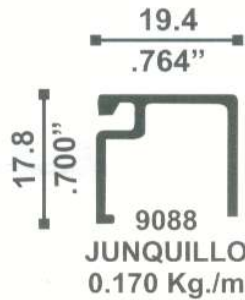
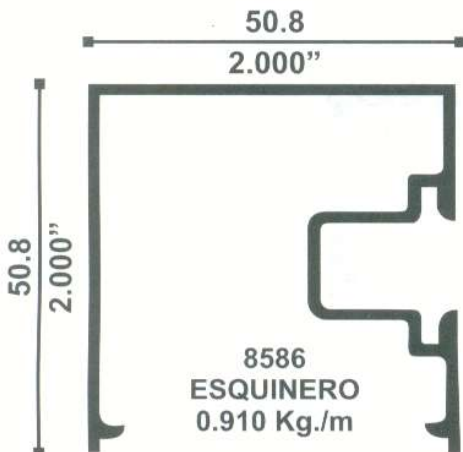
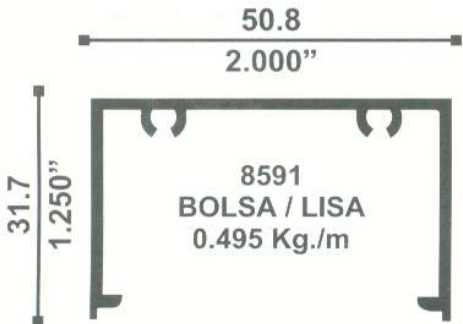
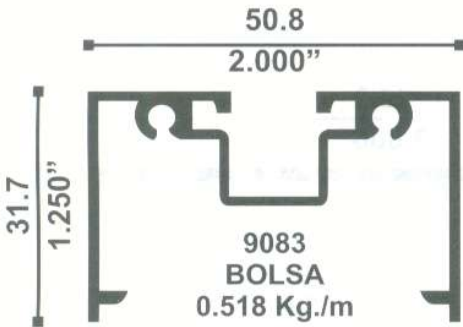

Largo Estándar 6.10 mts.

Distribuidor autorizado

**INDALUM, S.A.**  
LA MÁS AVANZADA EN ALUMINIO

Calidad Certificada  
 ISO 9002

# Línea de 3"

## FIJOS BOLSA

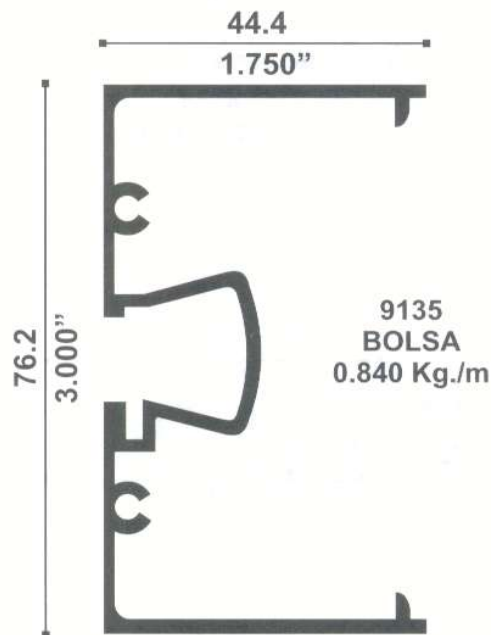

Largo Estándar 6.10 mts.

Distribuidor autorizado



Calidad Certificada  
ISO 9002

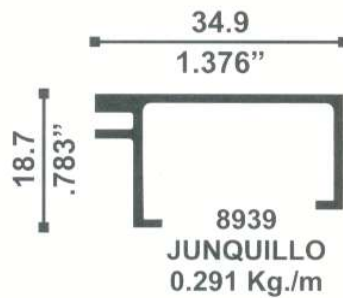
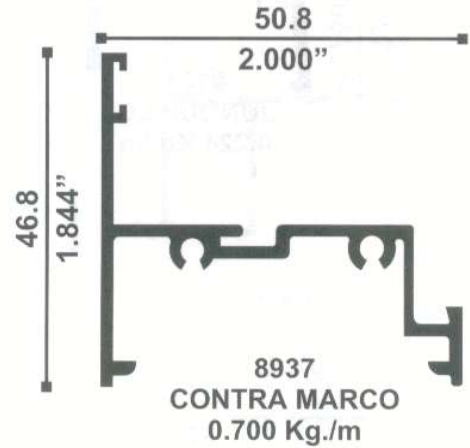
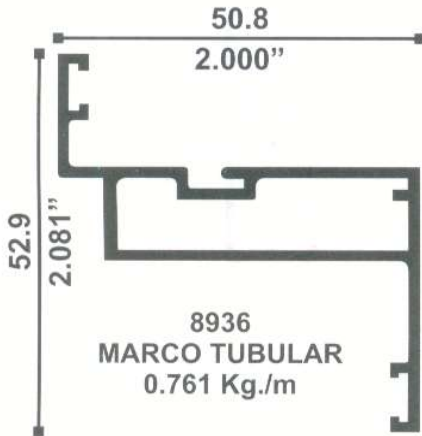

*Largo Estándar 6.10 mts.*

Distribuidor autorizado



Calidad Certificada  
ISO 9002

# Línea de 3"

## FIJOS BOLSA

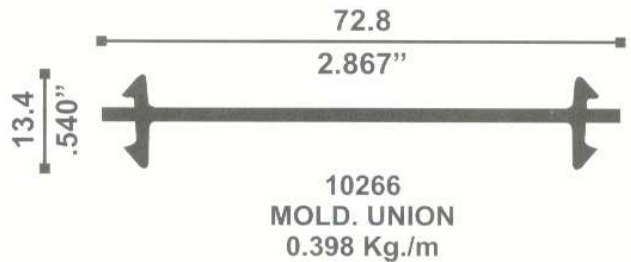
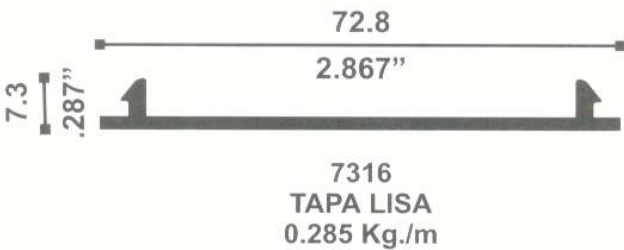
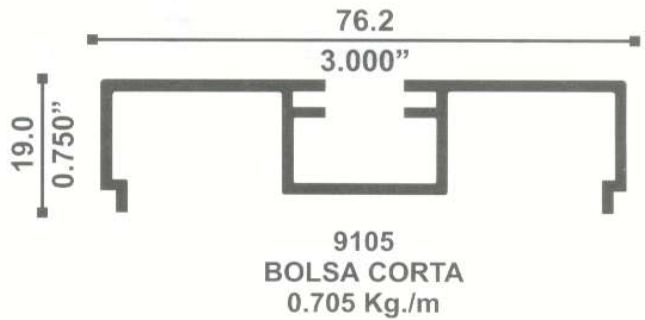
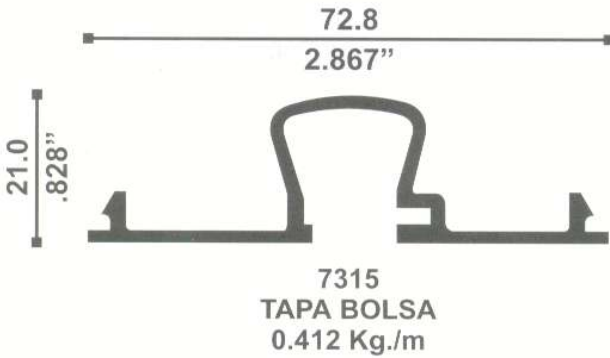
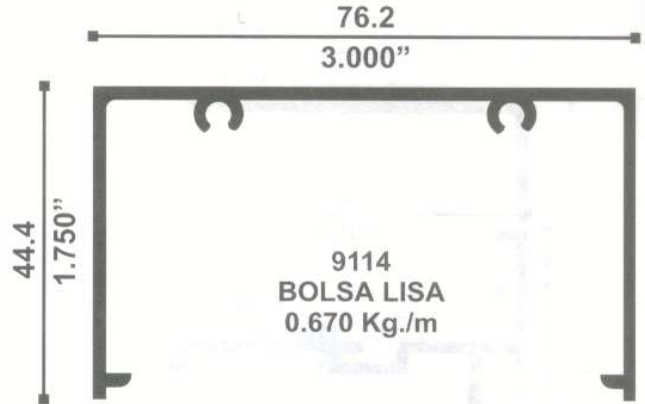
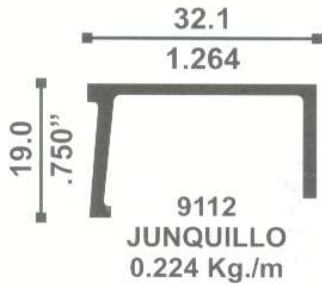

Largo Estándar 6.10 mts.

Distribuidor autorizado



Calidad Certificada  
ISO 9002



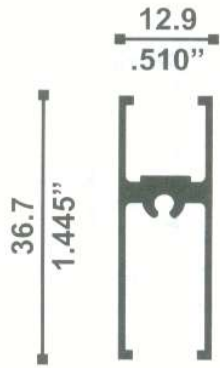

**11837**  
**CABEZAL Y ZOCLO**  
 0.246 Kg./m

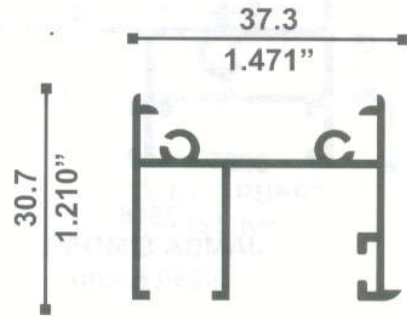

**11835**  
**JAMBA Y CABEZAL**  
 0.357 Kg./m

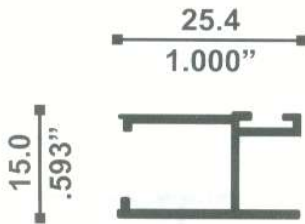

**11836**  
**CERCO TRASLAPE**  
 0.166 Kg./m

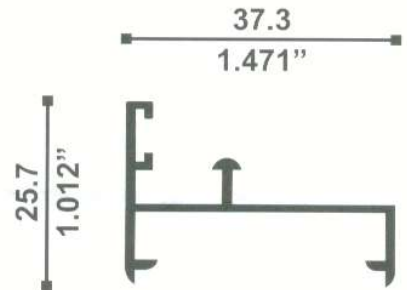

**11838**  
**RIEL**  
 0.250 Kg./m

*Largo Estándar 6.10 mts.*

Distribuidor autorizado



Calidad Certificada  
 ISO 9002

# Línea de 2"

## CORREDIZAS

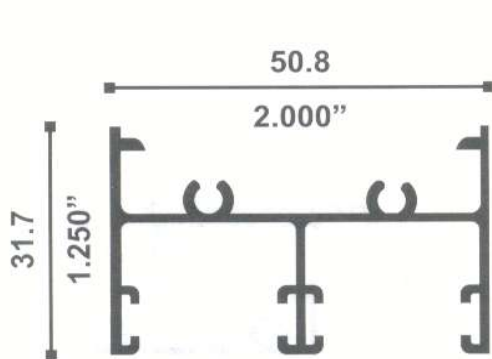

7518  
JAMBA S/MOSQ.  
0.590 Kg./m

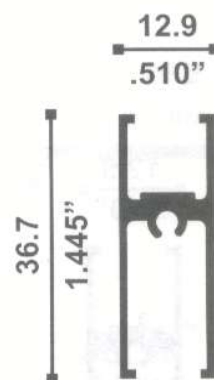

11837  
CABEZAL Y ZOCLO  
0.246 Kg./m

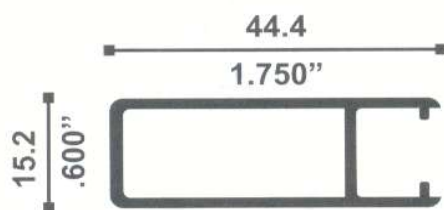

\*7821  
CERCO PUERTA  
0.380 Kg./m

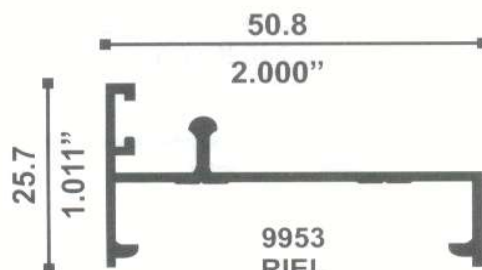

9953  
RIEL  
0.419 Kg./m

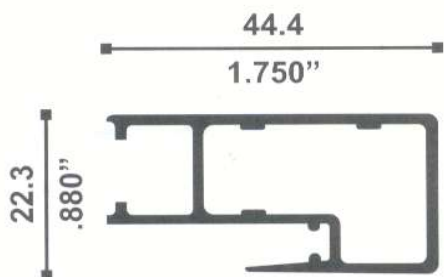

\*9955  
TRASLAPE PUERTA  
0.503 Kg./m

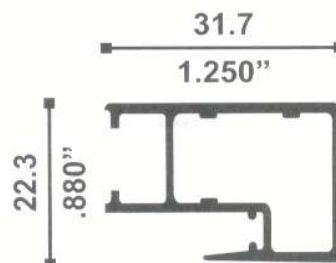

9954  
TRASLAPE VENTANA  
0.430 Kg./m

Largo Estándar 6.10 mts.

\* Largo 4.60 mts.

Distribuidor autorizado



Calidad Certificada  
ISO 9002

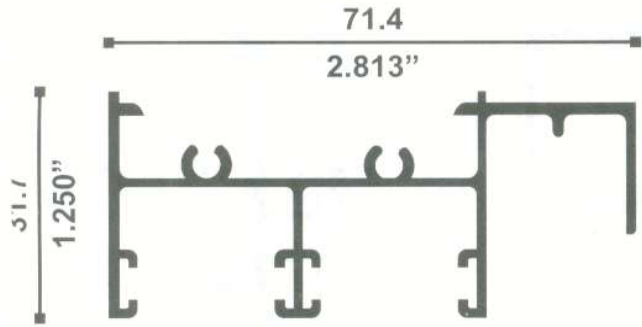

**7819**  
**JAMBA CON MOSQUITERO**  
 0.780 Kg./m

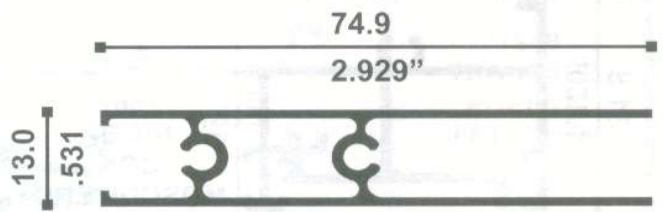

**7825**  
**ZOCLO PUERTA**  
 0.695 Kg./m

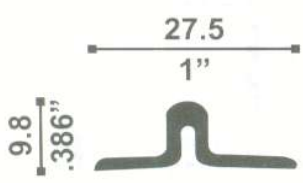

**7818**  
**RIEL ADICIONAL**  
 0.191 Kg./m

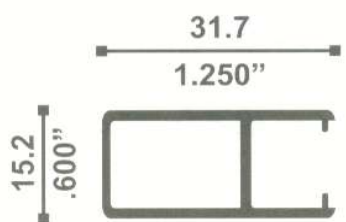

**8320**  
**CERCO VENTANA**  
 0.319 Kg./m

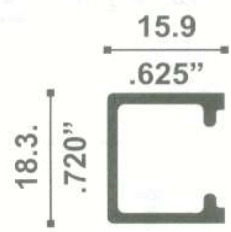

**7525**  
**CERCO FIJO ECONOMICO**  
 0.224 Kg./m

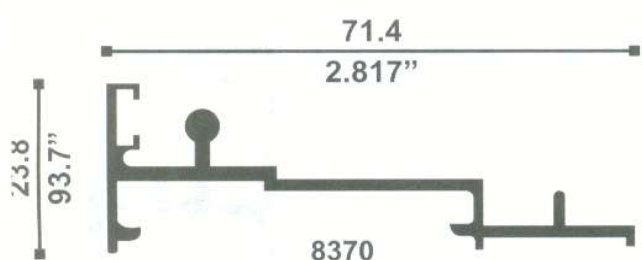

**8370**  
**RIEL CON MOSQUITERO**  
 0.646 Kg./m

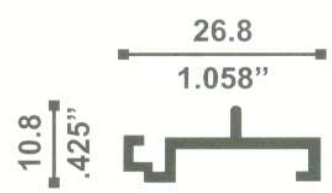

**9966**  
**ADAPTADOR MOSQUITERO**  
 0.176 Kg./m

Largo Estándar 6.10 mts.

Distribuidor autorizado  
**INDALUM, S.A.**

LA CALIDAD EN ALUMINIO

Calidad Certificada  
 ISO 9002

# Línea de 3"

## CORREDIZAS

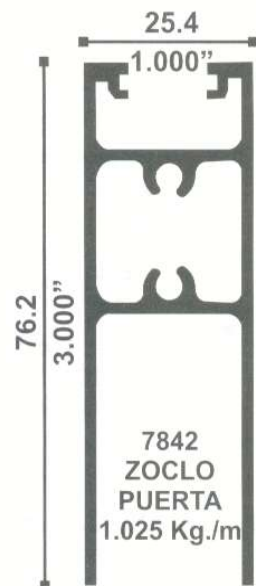
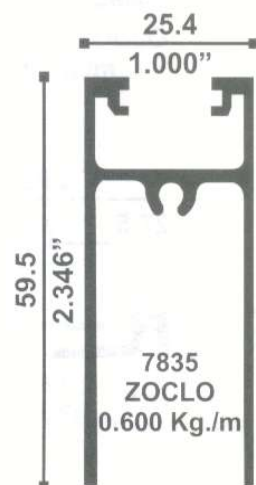
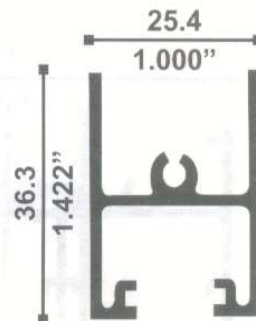
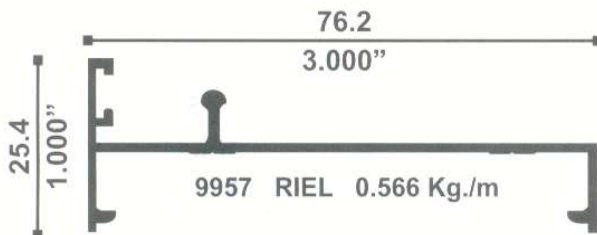
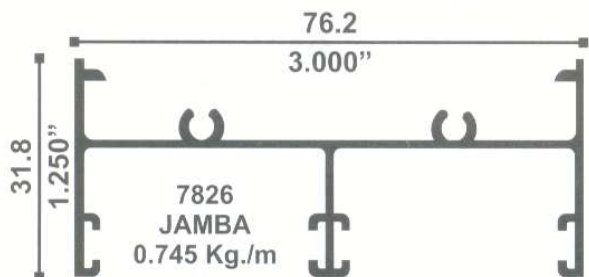
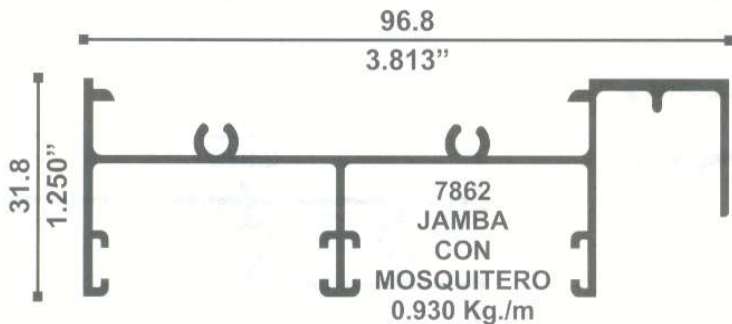

Largo Estándar 6.10 mts.

\* Largo 4.60 mts.

Distribuidor autorizado



Calidad Certificada  
ISO 9002

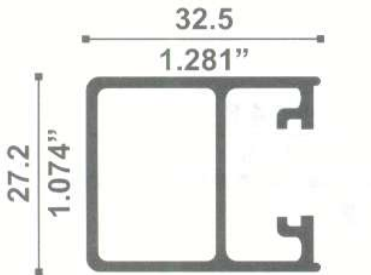

7843 CERCO JALADERA  
 VENTANA 0.576 Kg./m

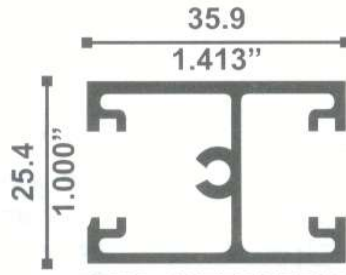

9082 INTERMEDIO  
 0.591 Kg./m

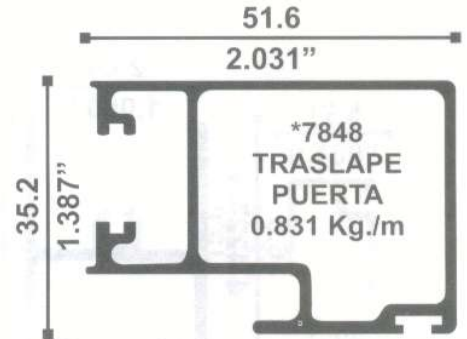

\*7848  
 TRASLAPE  
 PUERTA  
 0.831 Kg./m



\*7847  
 CERCO PUERTA  
 0.680 Kg./m

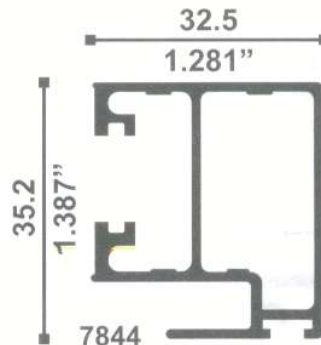

7844  
 CERCO TRASLAPE  
 VENTANA 0.627 Kg./m

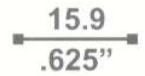

\*6534  
 CERCO  
 MOSQUITERO  
 VERTICAL  
 0.425 Kg./m

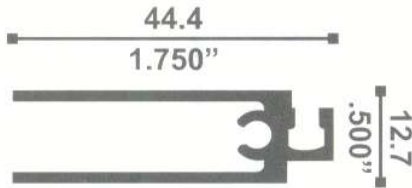

6533 CERCO MOSQUITERO  
 HORIZONTAL 0.378 Kg./m



8681  
 CERCO FIJO  
 0.328 Kg./m

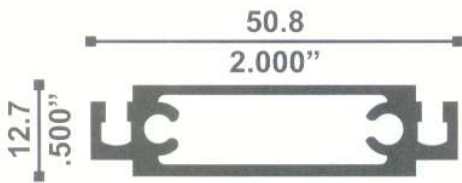

7101 INTERMEDIO MOSQUITERO  
 0.584 Kg./m

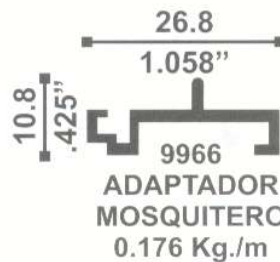

9966  
 ADAPTADOR  
 MOSQUITERO  
 0.176 Kg./m



7828 ADAPTADOR XX  
 0.243 Kg./m

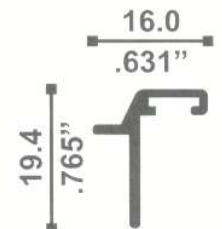

10220  
 ADAPTADOR OXXO  
 0.134 Kg./m

Largo Estándar 6.10 mts.  
 \*Largo 4.60 mts.

Distribuidor autorizado



Calidad Certificada  
 ISO 9002

# Puerta Batiente 1.00"

**ECONOMICA**

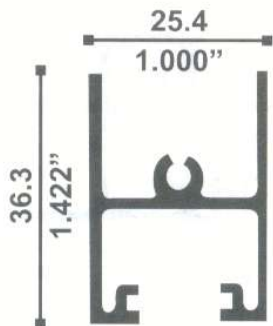

7836  
CABEZAL  
0.482 Kg./m

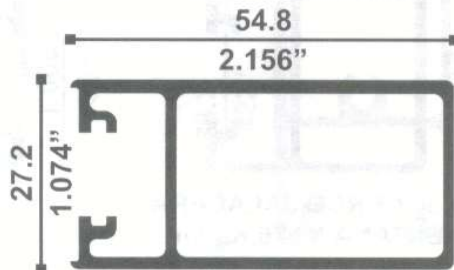

\* 7847  
CERCO CHAPA  
3.445 kg./m

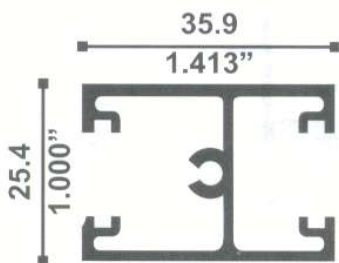

9082  
INTERMEDIO  
0.612 Kg./m



11032  
BATIENTE  
0.117 Kg./m

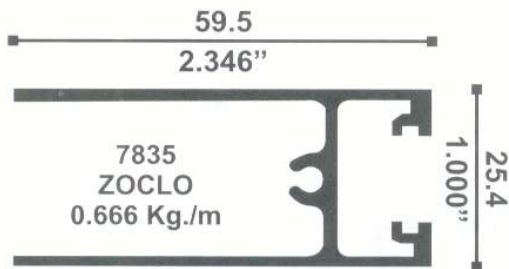

7835  
ZOCLO  
0.666 Kg./m



7842  
ZOCLO PUERTA  
1.025 Kg./m

Largo Estándar 6.10 mts.

\* Largo 4.60 mts.

Distribuidor autorizado



Calidad Certificada  
ISO 9002

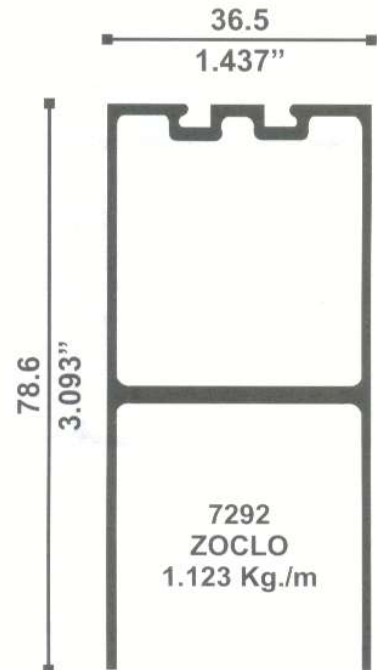
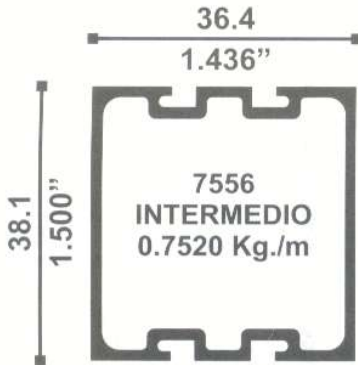
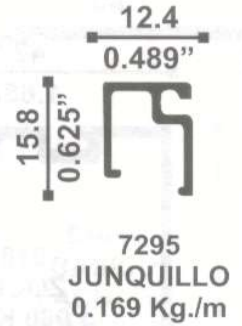
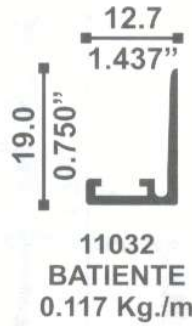
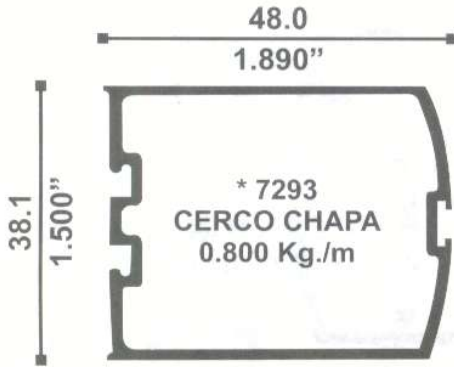

Largo Estándar 6.10 mts.  
 \* Largo 4.60 mts.

Distribuidor autorizado



Calidad Certificada  
 ISO 9002

# Línea 1.750"

## BATIENTES Y CANCELERIA INTERIOR 1750

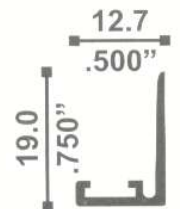
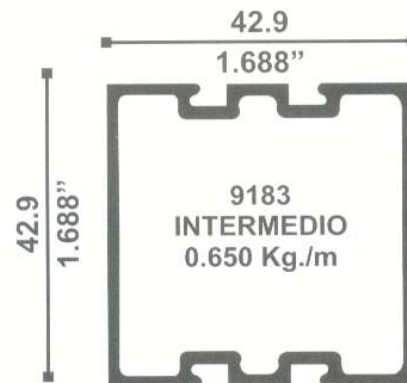
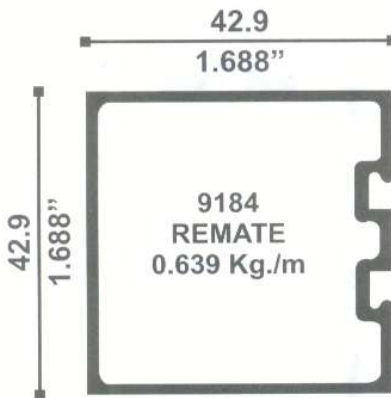
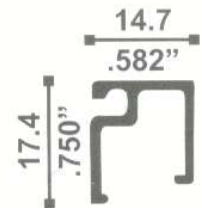
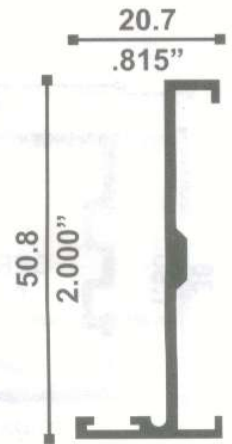
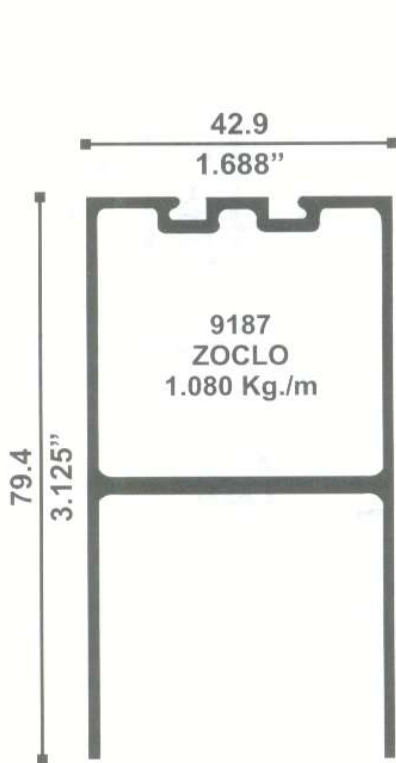

Largo Estándar 6.10 mts.  
\* Largo 4.60 mts.

Distribuidor autorizado



Calidad Certificada  
ISO 9002





Largo Estándar 6.10 mts.

Distribuidor autorizado



Calidad Certificada  
 ISO 9002

# Línea Perfiles Diversos

## FACHADA, PASAMANOS Y DIVERSOS

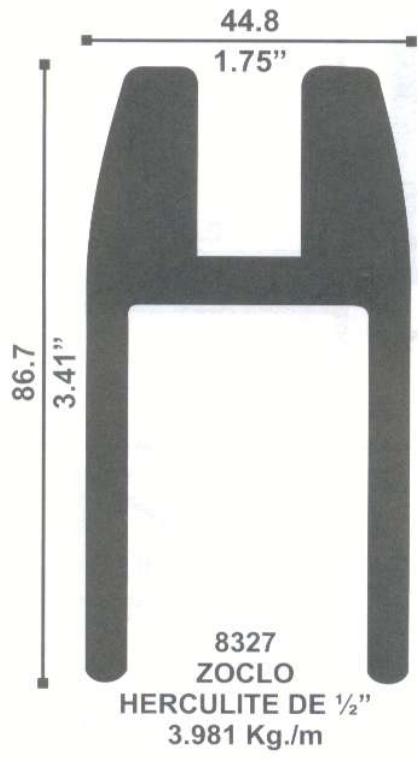
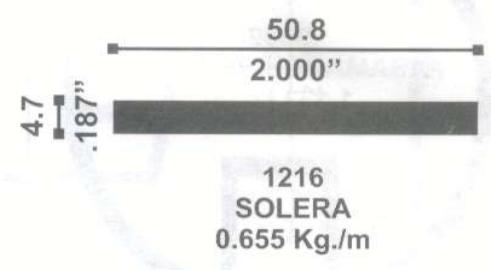

Largo Estándar 6.10 mts.  
\* Largo Estandar 3.66 mts.

Distribuidor autorizado  
**INDALUM, S.A.**  
LA MÁS ALTA CALIDAD EN ALUMINIO  
Calidad Certificada  
ISO 9002

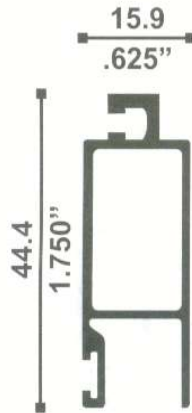

\*6534  
 CERCO MOSQUITERO  
 VERTICAL 0.425 Kg./m

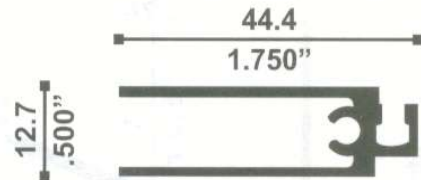

6533  
 CERCO MOSQUITERO  
 HORIZONTAL  
 0.378 Kg./m

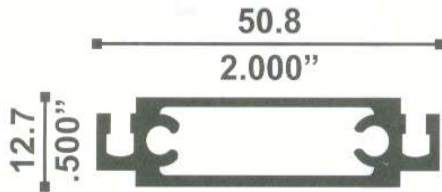

7101  
 INTERMEDIO MOSQUITERO  
 0.584 Kg./m

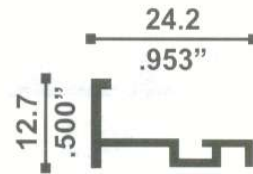

7013  
 PORTA VIDRIO  
 0.163 Kg./m

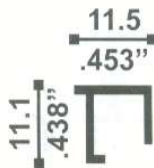

7014  
 JUNQUILLO  
 0.101 Kg./m



3188  
 MOLDURA ALFOMBRA  
 0.126 Kg./m

Largo Estándar 6.10 mts.  
 \* Largo 4.60 mts.

Distribuidor autorizado



Calidad Certificada  
 ISO 9002

# Línea Perfiles Diversos

## MOSQUITEROS RIELES Y VITRINAS

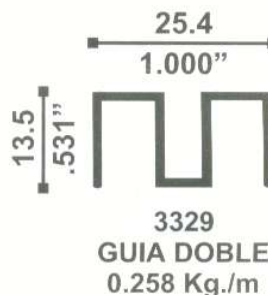
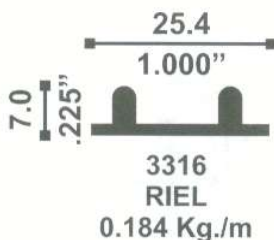
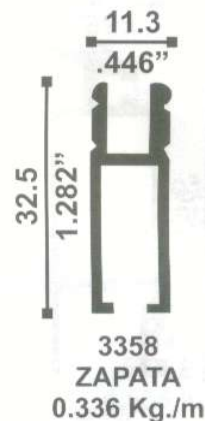

Largo Estándar 6.10 mts.

Distribuidor autorizado



Calidad Certificada  
ISO 9002

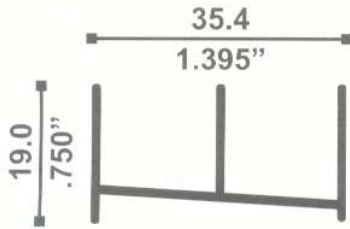

**11387**  
**RIEL INFERIOR**  
 0.233 Kg./m

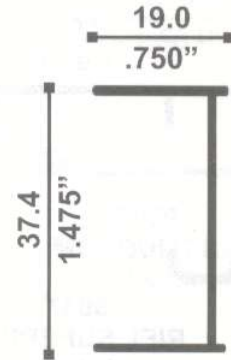

**\* 11386**  
**JAMBA LATERAL**  
 0.202 Kg./m

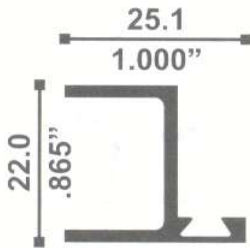

**7102**  
**BATIENTE STD.**  
 0.327 kg./m

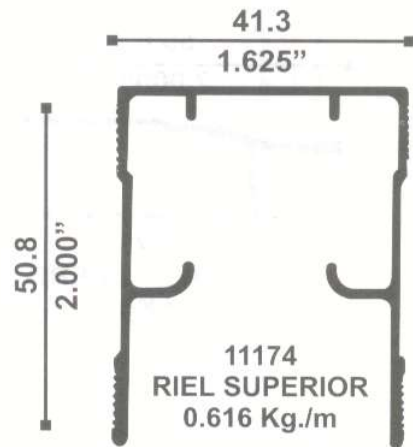

**11174**  
**RIEL SUPERIOR**  
 0.616 Kg./m

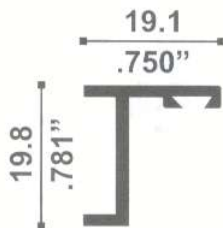

**4127**  
**BATIENTE**  
 0.186 Kg./m

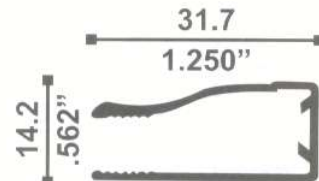

**9525**  
**MARCO 1 1/4''**  
 0.254 Kg./m

Largo Estándar 6.10 mts.

\* Largo 5.50 mts.

Distribuidor autorizado



Calidad Certificada  
 ISO 9002

# Linea de Baños

DE LUJO

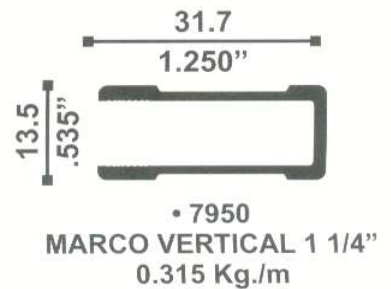
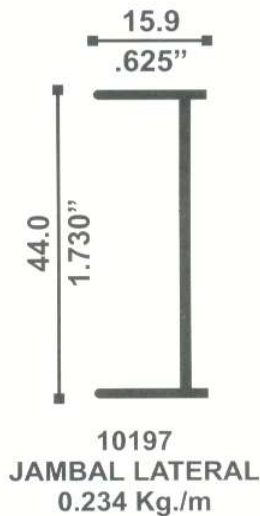
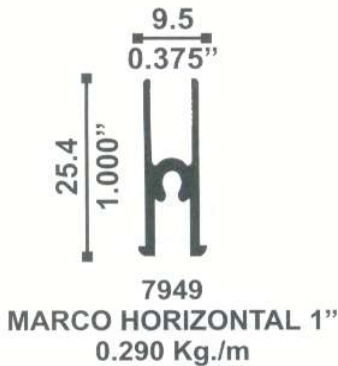
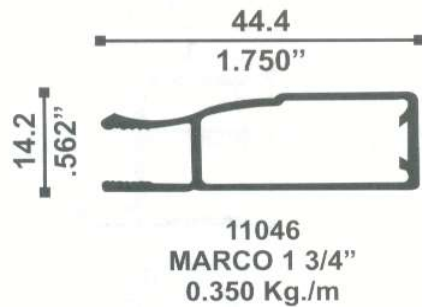
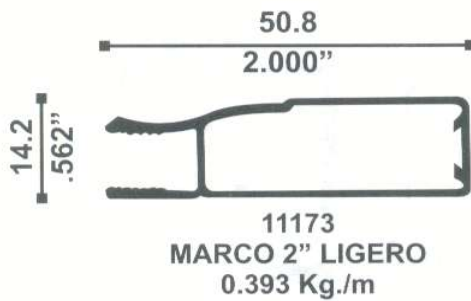
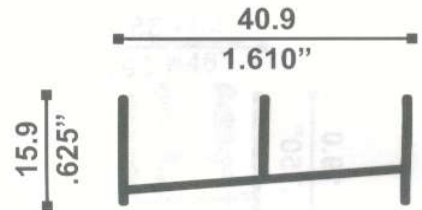
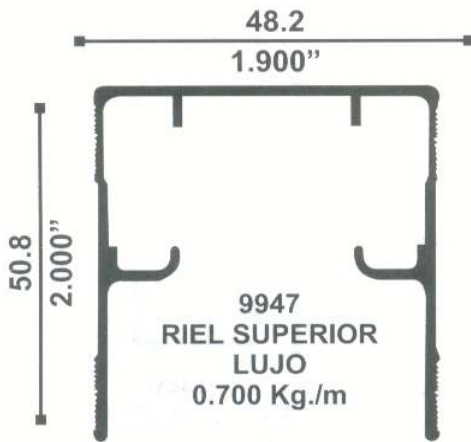

Largo Estándar 6.10 mts.

Distribuidor autorizado



Calidad Certificada  
ISO 9002

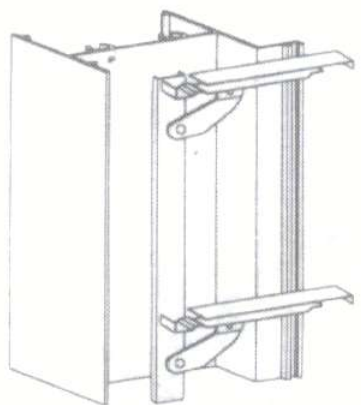

**JAMBA G-28**

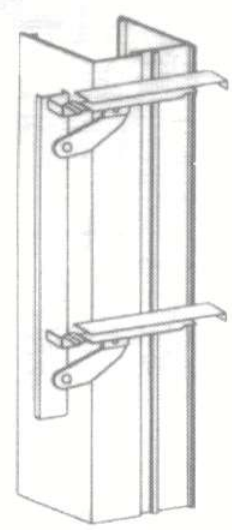
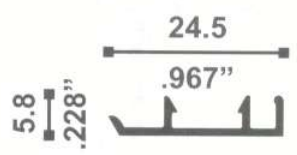

**JAMBA G-457**

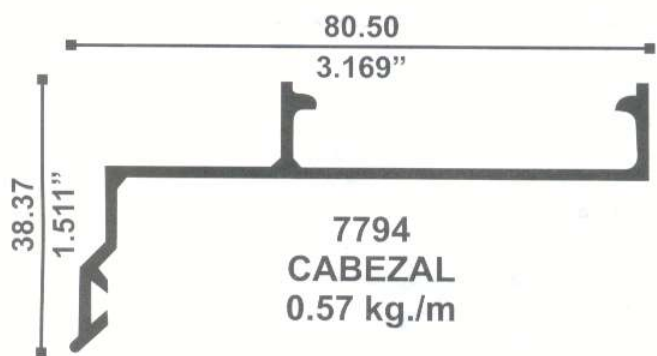

Largo Estándar 6.10 mts.

# Línea Recubrimientos

## DUELAS



Largo Estándar 6.10 mts.

\* Largo 5.00 mts.

Distribuidor autorizado



Calidad Certificada  
ISO 9002



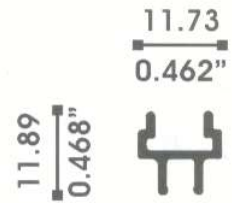
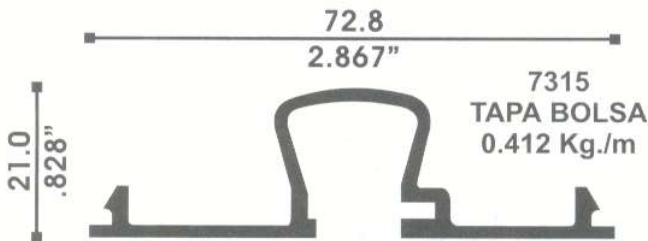
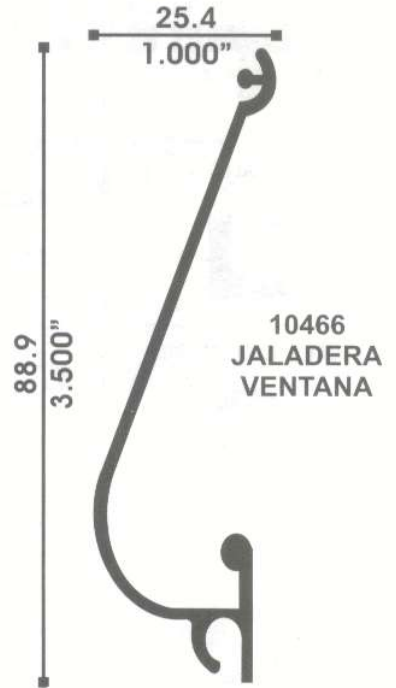
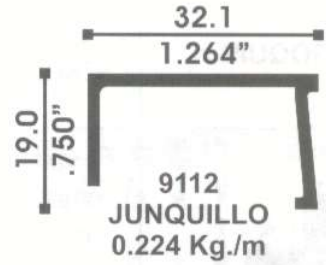
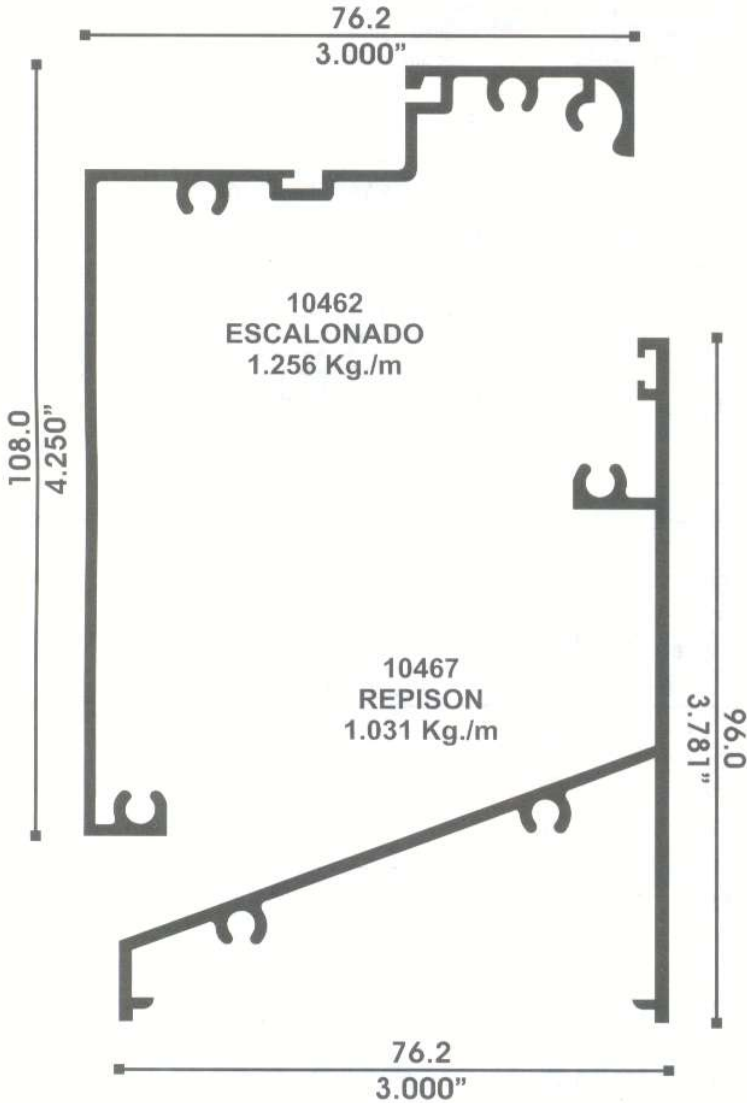

Largo Estándar 6.10 mts.

Distribuidor autorizado



Calidad Certificada  
 ISO 9002

# Linea de perfiles standard

Angulos, Tees, Canales, Tubos  
Redondos Cuadrados y Rectangulares



CROQUIS	No. PERFIL	CLAVE DE LARGO	DIMENSIONES EN PULGADAS			DIMENSIONES EN MILIMETROS			DATOS		
			A	B	C	A	B	C	PESO Kg/m	PERIM ANOD cms.	PERIM PULIDO cms.
<b>ANGULOS</b> 	11031		1/2	1/2	1/16	12.7	12.7	1.59	0.102	5.0	2.8
	11033		3/4	3/4	1/16	19.05	19.05	1.59	0.156	7.6	4.1
	11124		1.0	1.0	0.050	25.4	25.4	1.27	0.171	10.1	5.3
	1314		1 1/2	1 1/2	3/16	38.1	38.1	4.76	0.926	15.2	8.5
<b>TEES</b> 	1613		1.0	1.0	0.035	25.4	25.4	0.89	0.137	10.1	2.7
<b>CANALES</b> 	1435		0.350	0.350	0.040	8.9	8.9	1.0	0.060	5.2	2.64
	1433		1/2	1/2	0.035	12.7	12.7	0.89	0.088	7.44	3.99
<b>TUBOS REDONDEADOS</b> 	2121		1		0.050	25.4		1.27	0.261	7.9	7.9
	2131		3/8		0.050	9.52		1.27	0.89	9.9	9.9
	2152		1/2		0.050	12.70		1.27	1.150	11.9	11.9
<b>TUBOS CUADRADOS</b> 	11161		1.00	1.0	0.050	25.4	25.4	1.27	0.332	10.1	10.1
	11154		1 1/4	1 3/4	0.052	44.5	44.5	1.32	0.539	12.7	12.7
	11067		1 1/2	1 1/2	0.057	38.1	38.1	1.45	0.575	15.2	15.2
	11093		1 3/4	1 3/4	0.057	44.5	44.5	1.45	0.673	17.9	17.9
	2356		2	2	0.065	50.8	50.8	1.65	0.878	20.5	20.3
	2358 2365		3.000 4.000	3.000 4.000	0.083 0.125	1.694 3.386	30.48 40.64	30.48 40.64			
<b>TUBOS RECTANGulares</b> 	11086		1 1/2	3/4	0.050	38.1	19.05	1.27	0.376	11.43	11.43
	11121		2.00	1.00	0.057	50.8	25.4	1.45	0.574	15.2	15.2
	11099		2 1/2	1 1/4	1/16	63.5	31.75	1.69	0.786	19.0	19.0
	11122		3.00	1 3/4	0.078	76.2	44.45	2.0	1.251	24.1	24.1
	2520		4.00	1 3/4	0.078	101.6	44.45	2.0	1.526	29.2	29.2
<b>SOLERAS</b> 	1201		3/4	1/16	0.062	19.05	1.58		0.081	4.130	4.130
	1211		3/4	3/16	0.187	19.05	4.76		0.245	4.750	3.81
	1216		2.0	3/16	0.187	50.8	4.76		0.655	11.110	11.110

Distribuidor autorizado



Calidad Certificada  
ISO 9002